

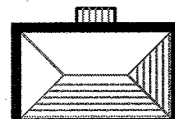





LEGEND:

- PROPOSED DWELLING 
- PROPOSED WELL 
- PROPOSED SDS 
- PROPOSED PROP. LINE 
- BUILDING SETBACK LINE 
- EXISTING UTILITY POLE 
- WETLAND LIMITS 
- SLOPES > 30% 
- EXISTING CONTOUR 
- SOILS LINE 

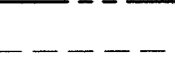
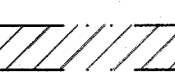
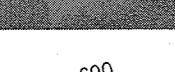
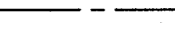

LOCATION MAP
SCALE: 1" = 2,000'

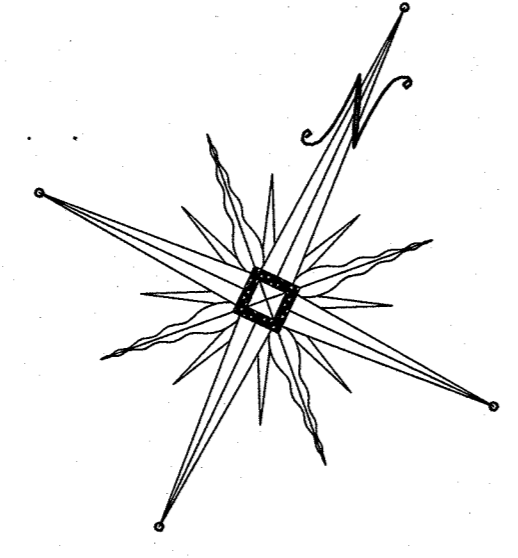
BULK REQUIREMENTS
AR-3 ZONING DISTRICT CLUSTERING REQUIRED
(USE GROUP-SINGLE FAMILY DETACHED DWELLING)

	MIN. REQUIRED	PROVIDED
LOT AREA (S.F.)	21,780	21,780
LOT WIDTH (FT.)	100	100
FRONT YARD (FT.)	35	35
SIDE YARD (FT.)	15	15
BOTH SIDE YARDS (FT.)	30	30
REAR YARD (FT.)	40	40
MAX. PERMITTED		
BLDG. COVERAGE (%)	20	20
BLDG. HEIGHT (FT.)	40	40

RECORD OWNER/APPLICANT
MEADOW HILL, LLC
48 JENNA DRIVE
MONROE, NEW YORK 10950

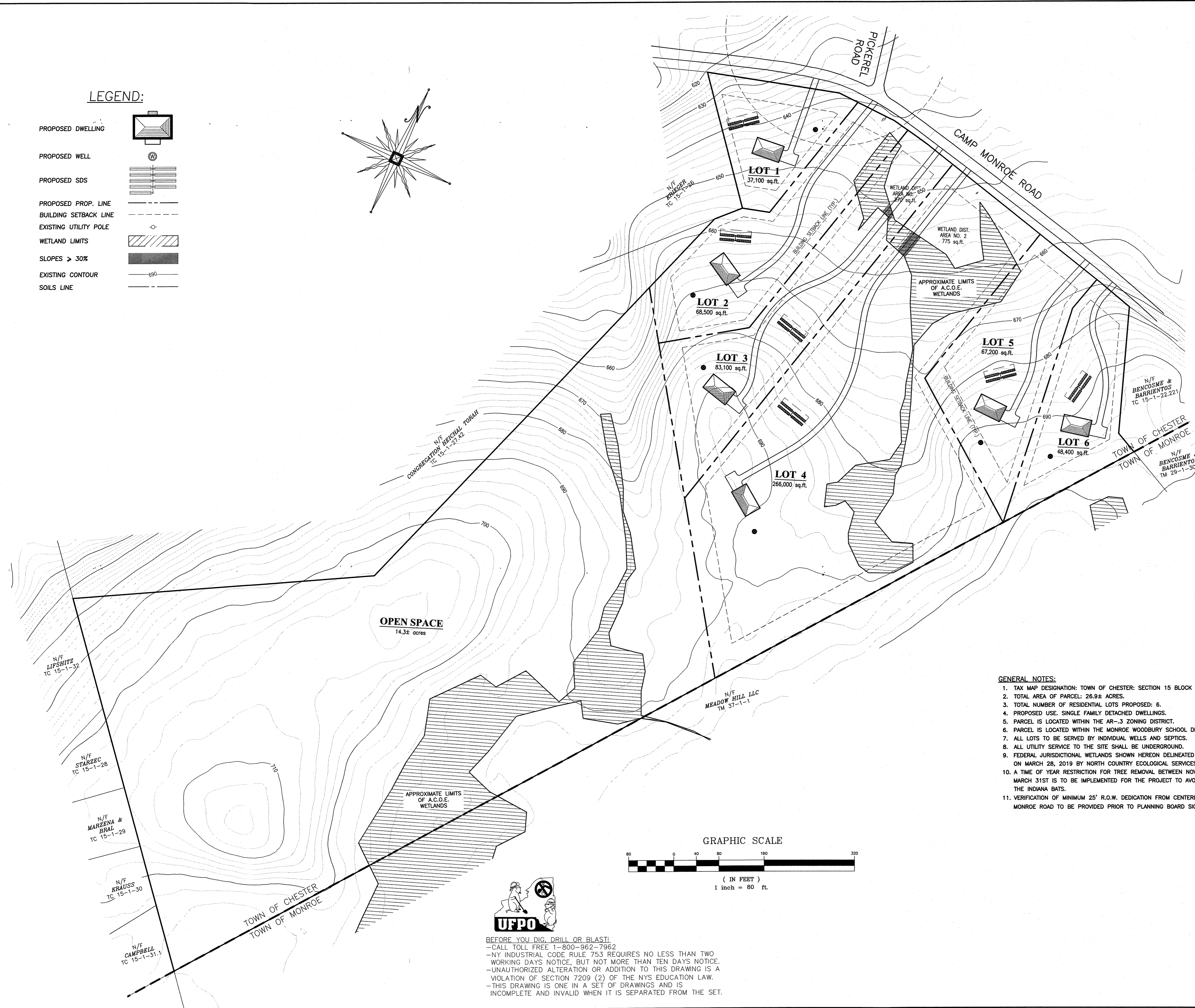

- GENERAL NOTES:**
- TAX MAP DESIGNATION: TOWN OF CHESTER; SECTION 15 BLOCK 1 LOT 27.41.
 - TOTAL AREA OF PARCEL: 26.9± ACRES.
 - TOTAL NUMBER OF RESIDENTIAL LOTS PROPOSED: 6.
 - PROPOSED USE, SINGLE FAMILY DETACHED DWELLINGS.
 - PARCEL IS LOCATED WITHIN THE AR-3 ZONING DISTRICT.
 - PARCEL IS LOCATED WITHIN THE MONROE WOODBURY SCHOOL DISTRICT.
 - ALL LOTS TO BE SERVED BY INDIVIDUAL WELLS AND SEPTICS.
 - ALL UTILITY SERVICE TO THE SITE SHALL BE UNDERGROUND.
 - FEDERAL JURISDICTIONAL WETLANDS SHOWN HEREON DELINEATED AND LOCATED ON MARCH 28, 2019 BY NORTH COUNTRY ECOLOGICAL SERVICES.
 - A TIME OF YEAR RESTRICTION FOR TREE REMOVAL BETWEEN NOVEMBER 1ST AND MARCH 31ST IS TO BE IMPLEMENTED FOR THE PROJECT TO AVOID IMPACTS TO THE INDIANA BAT.
 - VERIFICATION OF MINIMUM 25' R.O.W. DEDICATION FROM CENTERLINE OF CAMP MONROE ROAD TO BE PROVIDED PRIOR TO PLANNING BOARD SIGNATURE.

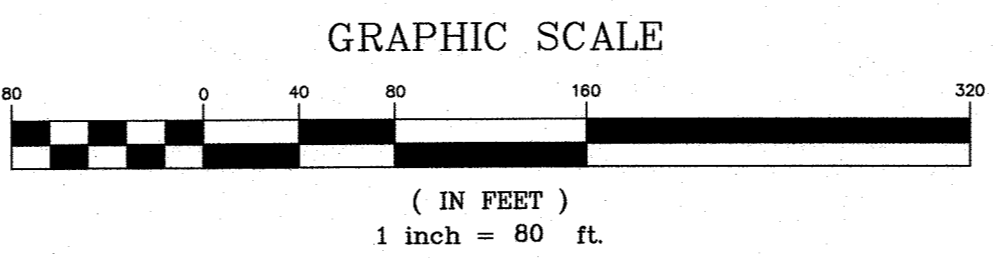

BEFORE YOU DIG, DRILL OR BLAST!
-CALL TOLL FREE 1-800-962-7962
-NY INDUSTRIAL CODE RULE 75.3 REQUIRES NO LESS THAN TWO WORKING DAYS NOTICE, BUT NOT MORE THAN TEN DAYS NOTICE.
-UNAUTHORIZED ALTERATION OR ADDITION TO THIS DRAWING IS A VIOLATION OF SECTION 7209 (2) OF THE NYS EDUCATION LAW.
-THIS DRAWING IS ONE IN A SET OF DRAWINGS AND IS INCOMPLETE AND INVALID WHEN IT IS SEPARATED FROM THE SET.

1-20-20	SKETCH PLAN PREPARATION DATE	JLP
DATE	DESCRIPTION	INITIALS
REVISIONS		
MAP CHECK DATE:	00/00/00	INITIALED BY: --

PIETRZAK & PFAU
ENGINEERING & SURVEYING, PLLC
282 GREENWICH AVENUE, SUITE A GOSHEN, NEW YORK 10924 (845) 284-0606
2 HAMILTON AVENUE MONTICELLO, NEW YORK 12701 (845) 796-4846

JOSEPH J. PFAU, P.E. LICENSE NO. 050223
MICHAEL F. CROGAN, P.L.S. LICENSE NO. 050223
VINCENT A. PIETRZAK, P.E., LEAD/CM
P.E. LICENSE NO. 078936 P.L.S. LICENSE NO. 050075
N.Y.P.S. LICENSE NO. 36396

SIGNATURE:  DATE: 1-20-20

OAK WOODS SUBDIVISION
TOWN OF CHESTER
COUNTY OF ORANGE, NEW YORK
SECTION 15 BLOCK 1 LOT 27.41

PROJECT TITLE

SKETCH CLUSTER PLAN

DRAWING TITLE

UNAUTHORIZED ALTERATION OR ADDITION TO A PLAN BEARING A LICENSED LAND SURVEYOR'S OR PROFESSIONAL ENGINEER'S SEAL IS A VIOLATION OF SECTION 7209, SUB-DIVISION 2 OF THE N.Y. STATE EDUCATION LAW.

O.C.H.D. SHEET NO. N/A	D.E.C. SHEET NO. N/A	DRAWING NUMBER 1 OF 1
SCALE 1"=80'	CAD REFERENCE 181221 Wetlands.dwg	PROJECT NUMBER 18122.01